



White Paper ATSC 3.0 Overview

April, 2017

ATSC 3.0

Next-Gen Digital Broadcast Standard

COMARK
Communications

ATSC 3.0 Overview

Table of Contents

- Introduction 3
- Capabilities 4
- Market and Business Realities 6
- ATSC 3.0 Technical Overview 7
 - Frame Structure 7
 - Physical Layer Pipes 8
 - ModCod 8
- System Capacity 9
- Simplified Architecture 10
 - System Resource Manager 10
 - Broadcast Gateway 11
 - IP Contribution Network 11
 - DTV Exciter 12
- DTV Transmitter Considerations 12
- ATSC 3.0 Acronyms and Glossary 14

➤ **Introduction**

ATSC 3.0 will revolutionize the broadcast industry bringing technologies, capabilities and complexities never dreamed 20+ years ago when the first generation ATSC standard was being developed. The purpose of the document isn't to review the standard in detail, but rather to provide the reader with an overview of the standard and more importantly how the various components and subsystems will be implemented to deploy an ATSC 3.0 broadcast.

ATSC 3.0 has been developed under the supervision of the Technology Standards Group known as TG3. TG3 has several Specialist Groups that have been created to manage the standards development work including:

- TG3/S31 – Specialist Group on System Requirements and Program Management
- TG3/S32 – Specialist Group on Physical Layer for ATSC 3.0
- TG3/S33 – Specialist Group on Management and Protocols
- TG3/S34 – Specialist Group on Applications and Presentations for ATSC 3.0
- TG3/S35 – Specialist Group on ATSC 3.0 Ecosystem
- TG3/S36 – Specialist Group on ATSC 3.0 Security

Each Specialist Group has one or more Ad-Hoc Groups that have been assigned specific parts of the standard development. The diagram below shows the hierarchy of TG3 including the Specialist Groups and Ad Hoc Groups.

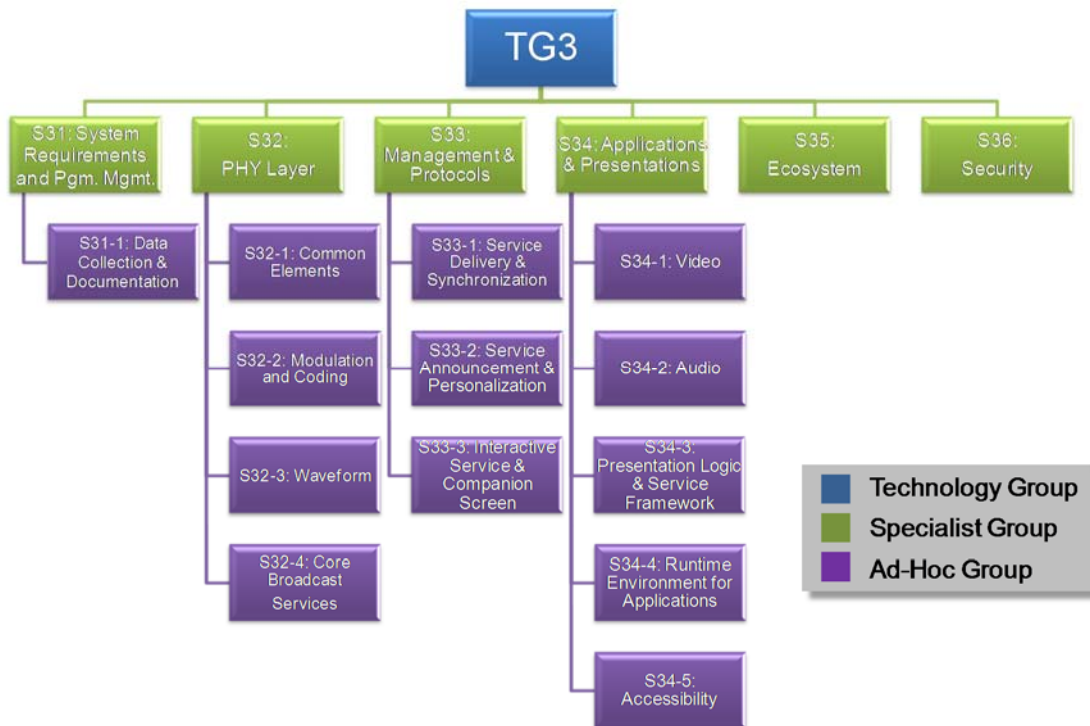

Due to the complexity of the new standard, it has been divided up by ATSC amongst 20 different subparts. This expedites time to market by dividing the workload for conceptual design and the associated document drafting.

As previously noted, ATSC 3.0 is comprised of twenty different subparts / documents. As of the creation of this document, most of the standards are in a preliminary release known as “Candidate Standard” with full approval of the full suite of documents expected towards the end of 2016 or early 2017. Therefore, some parts of the full system are still under development. With that being noted, the diagram below shows the breakdown of all the different subparts that encompass ATSC 3.0 as well as how they fit into a layered “OSI-like” protocol stack.

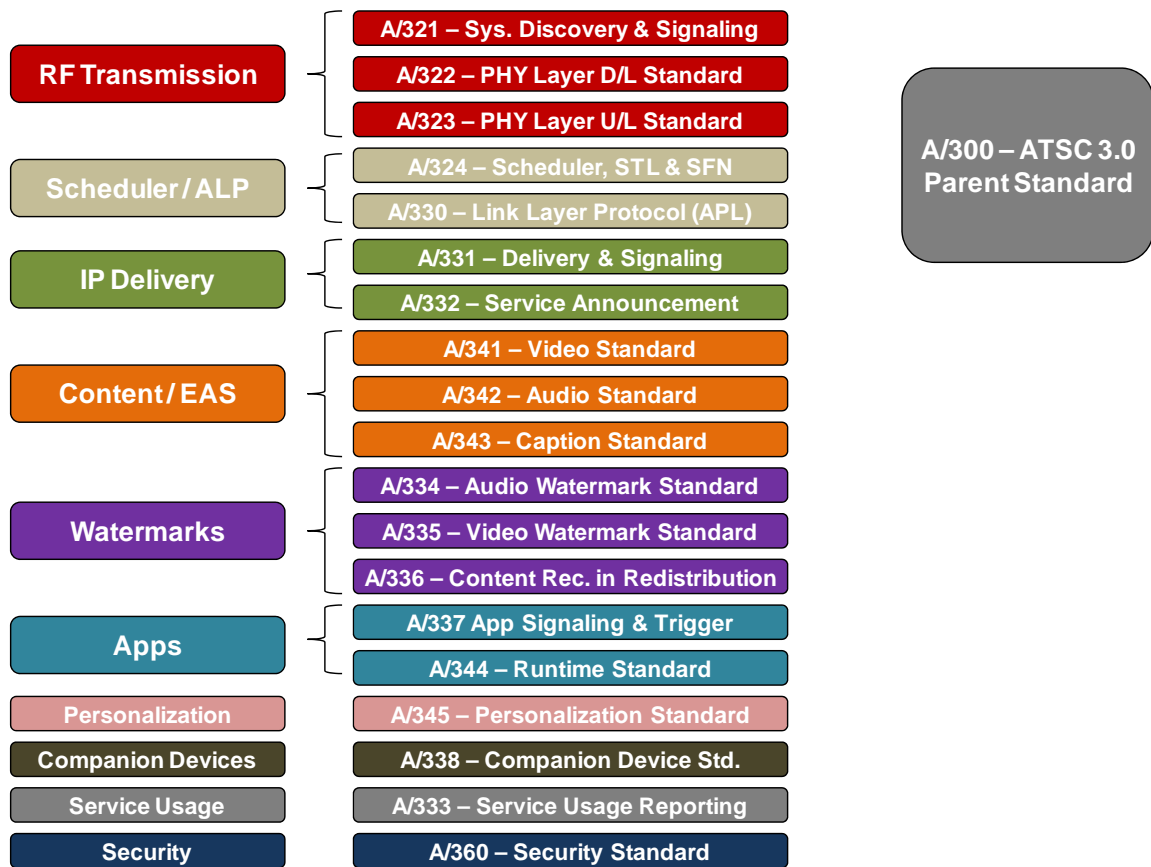

➤ **Capabilities**

Why ATSC 3.0? Simple answer is that it’s time for a new DTV standard that allows broadcasters to serve new market requirements. ATSC 1.0 is approximately 20 years old; the standard was approved in 1995 and subsequently adopted by the FCC in 1996. At that time there was no smart phone (iPhone released in 2007), no OTT service (Netflix started their internet based streaming service in 2007), and no tablet PC’s (iPad released in 2010). Gigabit Ethernet didn’t start being

deployed until 1999. The first version of Wi-Fi {802.11 protocol} was released in 1997 and provided up to 2 Mbps link speeds. 802.11b was updated in 1999 with 11 Mbps link speeds.

Technology continues to march forward and broadcasters need the tool set that allows them to compete with wireless and Telco companies. Keep in mind that media consumption by consumers has changed and will continue to change:

- One-to-many (the “Golden Era” of broadcast TV, 4 major networks)
- One-to-“less than many” (more networks with specialized content, CNN, HGTV, ESPN)
- Linear TV: consumers watch content when the networks control the schedule
- VCR ► DVR/PVR: consumers get to choose **when** “we” watch it
- OTT: Consumers to choose **what** “we” want, **when** “we” want to watch
- Mobile Video: Allows consumers to control **where, when, and what**
- What’s next?

ATSC 3.0 is a clean sheet of paper to create a new DTV standard from the ground up. ATSC 3.0 has been designed to be flexible; allowing broadcasters to deliver small screen content up to UHD TV to mobile and/or fixed receivers. It will allow broadcasters to utilize high tower / high transmitter architectures as well as cellular line SFN architectures. ATSC 3.0 integrates linear and non-linear, broadcast and IP as well as interactivity. The only draw-back of ATSC 3.0 is that it is not backwards compatible with ATSC 1.0.

ATSC 3.0 has been designed to utilize the most efficient technologies including error correction coding, compression algorithms, and modulation and coding schemes. The system has been designed to support:

- UHD (4K) ~ 3840 x 2160 {or 8K @ 7680 x 4320} at 60 frames per second (fps)
- HDR (High Dynamic Range) 1080 x 1920 Progressive at 60 (fps)
- Robust Services delivered to mobile devices (tablets and smart phones)
- High efficiency video compression (HEVC/H.265)
- Companion screens (aka 2nd screen experiences)
- Broadband connectivity
- Seamless convergence of both OTA and online content delivery
- OFDM waveform with 1Mbps up to 57Mbps in a 6MHz channel (28Mbps typical)



Since we cannot predict the future applications that consumers will adopt, ATSC 3.0 is being designed to be future proof. This is being ensured through a design that is both flexible and extensible so that new technologies, functionalities, and Services can easily be added in the future.

➤ **Market and Business Realities**

There are market and business realities of the broadcast market that must be dealt with. Market realities include the fact that there are numerous ATSC 1.0 receivers currently in use throughout the country. Also, for a station converting from ATSC 1.0 to 3.0, there will be no companion channel allocated for stations looking to transition. Lastly, it is difficult to predict how broadly the broadcast and Consumer Electronic (CE) industries will support the adoption of the new DTV standard.

Business realities include the very pertinent question as to how will broadcasters make money off ATSC 3.0? Will broadcasters implementing ATSC 3.0 utilize a traditional model of linear TV distribution (SD / HD / UHD)? Or will broadcasters look for new business opportunities through new advertising models, subscription fees, and/or retransmission rights and their associated fees? Finally, will the consumer electronics manufacturers adopt and integrate ATSC 3.0 tuners into tablet PC's, 4G devices, and what about an ATSC 3.0 tuner integrated into the next big thing or device of the future?



➤ ATSC 3.0 Technical Overview

ATSC 3.0 has many capabilities and features. As such the details of the standard are beyond the scope of this document. However this document will provide some high level details to describe the functions of the standard.

Frame Structure

ATSC 3.0 uses a frame structure that includes three primary components. These components include the bootstrap, preamble, and one or more subframes with data (see diagram below). The frame duration can be variable length with 50ms being the smallest and up to 5s the longest permitted frame length. Most systems will likely be setup with a frame length of between 250ms to 1s due to implications of live content processing. A frame can be setup to carry a variety of modulation types, FFT sizes, FEC strategies to allow multiple Services each with their own Quality of Service (QoS) in a single RF transmission.

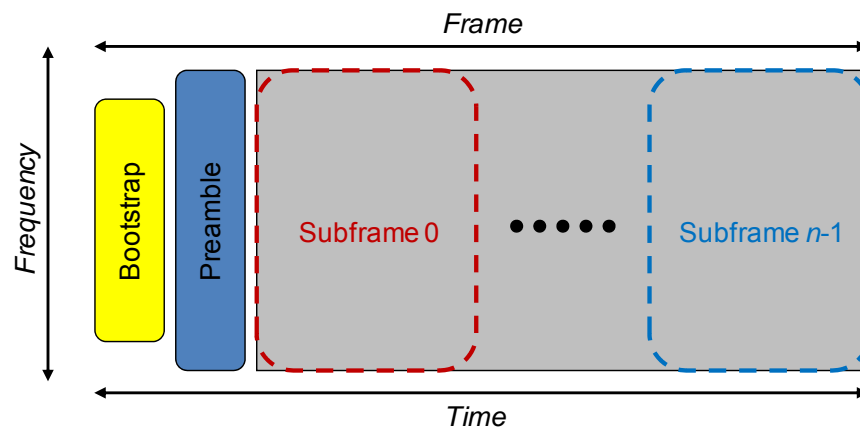

The bootstrap has been designed to allow receivers to quickly and easily detect the RF signal. The bootstrap is extremely robust for reception in the most difficult RF channel circumstances. It contains the necessary data to demodulate the preamble. The bootstrap has a fixed modulation configuration including 4.5MHz bandwidth and a short 500 microsecond duration. The bootstrap is also able to indicate the version of the frames following, which means future versions such as ATSC 3.1 can be signaled via the bootstrap.

The Preamble immediately follows the bootstrap. It is responsible for defining the parameters required by the receiver to demodulate and decode the rest of the frame. The preamble has two parts including Layer 1-Basic and Layer 1-Detail. L1-Basic is fixed at 200 bits and contains information that allows the receiver to decode L1-Detail. The L1-Basic provides the most fundamental signaling information which is static over the complete frame. L1-Detail is a variable length and provides the remaining details that are required for the receiver to decode the data subframes (payload). There is a lot more details of the frame structure that are outside the scope of the document that are available in the standard documents.

Physical Layer Pipes

A concept that is new to users of ATSC is the use of Physical Layer Pipes (PLP). PLPs have been used in the DVB-S2 and DVB-T2 world for a while. A PLP allows a Service to be assigned to a specific reception robustness requirement. For instance, a mobile Service requires more robust (lower C/N) delivery than a fixed Service (higher C/N). Multiple PLP's can be combined (up to 64 for ATSC 3.0) into a single RF transmission allowing delivery of multiple Services (mobile, SD, HD, HDR, EAS) or even use multiple (4 PLP's) for delivery of a single Service (PLP0 = video, PLP1 = audio, PLP2 = metadata, PLP3 = ESG). The diagram below provides just one simple example of PLP usage.

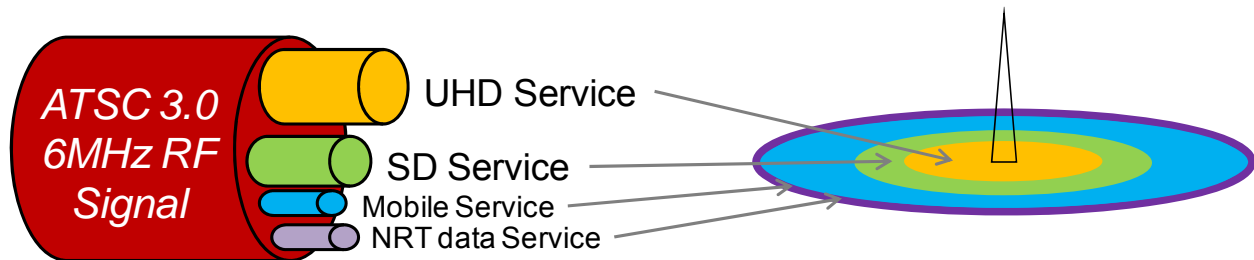

ModCod

The flexibility of ATSC 3.0 lies in the numerous combinations of Error Corrections and ModCod assigned to each PLP. ModCod is the combination of **Modulation** and **Coding** rate that together determine the size of the baseband packet. Not all combinations of modulation and coding are mandatory in ATSC 3.0; the tables below show the combinations that are mandatory.

Code Rate/ Constellation	2/ 15	3/ 15	4/ 15	5/ 15	6/ 15	7/ 15	8/ 15	9/ 15	10/ 15	11/ 15	12/ 15	13/ 15
QPSK	✓	✓	✓	✓	✓	✓	✓	✓		✓		
16QAM			✓	✓		✓	✓	✓		✓		
64QAM		✓	✓	✓	✓	✓	✓	✓	✓	✓		
256QAM			✓	✓		✓	✓	✓	✓	✓	✓	✓
1024QAM				✓		✓	✓	✓	✓	✓	✓	✓
4096QAM						✓		✓		✓	✓	✓

Mandatory ModCod combinations with LDPC = 64000 bits

Code Rate/ Constellation	2/ 15	3/ 15	4/ 15	5/ 15	6/ 15	7/ 15	8/ 15	9/ 15	10/ 15	11/ 15	12/ 15	13/ 15
QPSK	✓	✓	✓	✓	✓	✓	✓	✓				
16QAM				✓	✓	✓	✓			✓		
64QAM				✓	✓	✓	✓	✓	✓	✓		
256QAM				✓		✓	✓	✓	✓	✓	✓	✓

Mandatory ModCod combinations with LDPC = 16000 bits

➤ **System Capacity**

ATSC 3.0 offers broadcasters a wide variety of flexibility to “tweak the knobs” to achieve the level of robustness / throughput that can deliver the desired Services to the targeted receivers. Using the 4 x PLP configuration shown previously (UHD, SD, Mobile, NRT data), the tables below show one possible configuration of the ATSC 3.0 parameters.

Service	PLP#	FFT	GI	Mod	Cod	Outer FEC	Inner FEC	Frame
UHD	PLP1	32k	148µS	256 QAM	13/15	BCH	64800	250mS
SD	PLP2	32k	148µS	64 QAM	10/15	BCH	64800	250mS
Mobile	PLP3	8k	148µS	QPSK	5/15	BCH	16200	100mS
NRT	PLP4	8k	148µS	QPSK	3/15	BCH	16200	100mS

Once the ATSC 3.0 system parameters are set on a per PLP basis, estimated capacity and performance calculations can be generated as shown below. UHD or multi-HD in PLP1 provides the highest data rate (17.3Mb/s), but the lowest SNR and Doppler performance. SD video Service(s) are allocated 5.5Mb/s and the SNR has improved by approximately 10dB. Finally for mobile and NRT Services, the less efficient ModCod combinations provide excellent SNR and Doppler performance. The 6MHz RF channel in this sample provides 23.6Mb/s in total data capacity. Higher capacities can be achieved with different ModCod combinations, but at the expense of higher SNR requirements. Each broadcaster will need to review their market specific requirements and “tweak the knobs” in the ATSC 3.0 system accordingly to meet their specific demands.

Service	PLP#	% Channel	PLP Capacity	AGWN SNR	Rayleigh SNR	Doppler
UHD	PLP1	45%	17.3Mb/s	22.2 dB	26.6dB	49 mph
SD	PLP2	25%	5.5Mb/s	12.9dB	15.8dB	49 mph
Mobile	PLP3	20%	0.58Mb/s	-1.3dB	-0.1dB	180 mph
NRT	PLP4	10%	0.17Mb/s	-3.7dB	-3.0dB	180 mph
Total		100%	23.6Mb/s			

➤ Simplified Architecture

In order to deploy ATSC 3.0, the DTV broadcast station requires implementation of several processing functions as indicated in the block diagram below. Note that IP networking has been specified throughout ATSC 3.0 and replaces traditional MPEG-2 transport stream interfaces used in ATSC 1.0 networks. Implementation of IP networking technology provides a higher level of interoperability and flexibility for equipment interconnectivity.

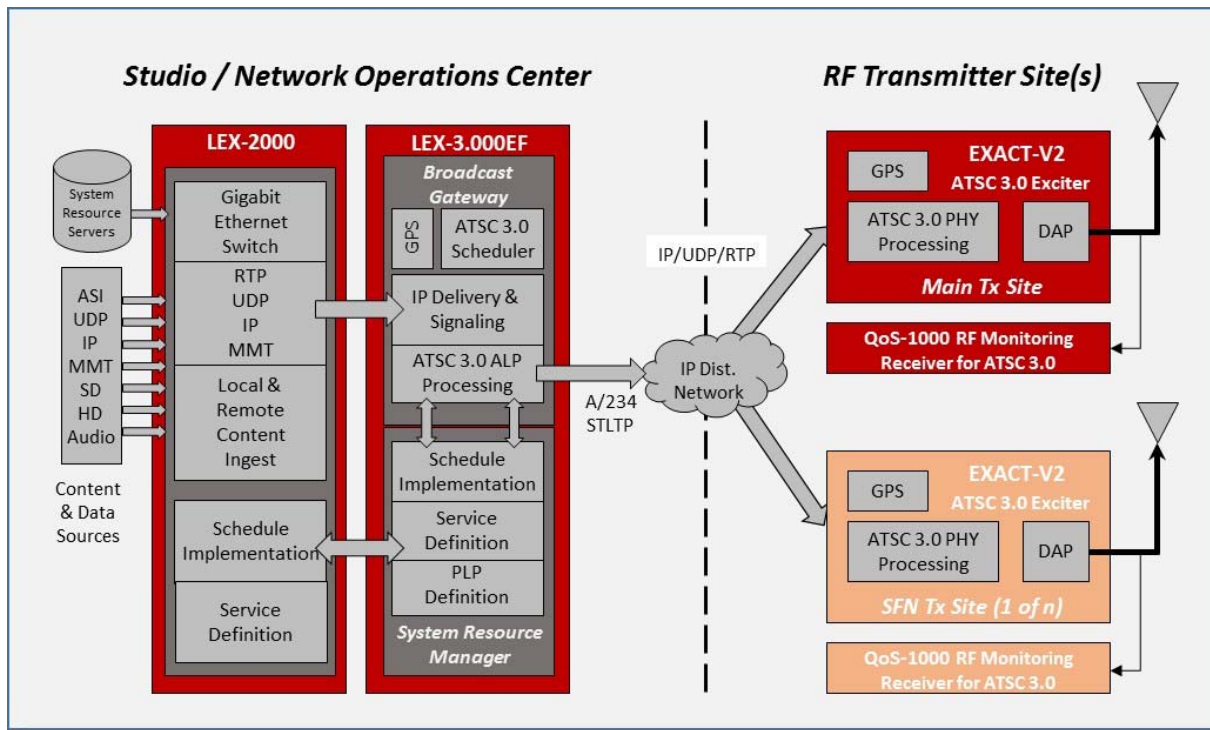

System Resource Manager

Starting at the studio or Network Operations Center (NOC) is the first major processor is called the **System Resource Manager (SRM)**. The SRM communicates the command and configuration data to the remainder of the equipment at the NOC using SMPTE-2021 (BXF) standard. BXF (Broadcast eXchange Format) standardizes the communication of three basic types of data exchange including:

1. Schedule and as run information
2. Content metadata
3. Content movement instructions

The SRM is responsible for the definition of the ATSC 3.0 broadcast configuration(s) and scheduling of these configurations (day time, prime time, etc.). The primary responsibility of the SRM is the definition of PLP configuration (number of PLP's per RF channel, configuration of each PLP, etc.). Once this is complete, the SRM assigns Services to the PLP's and then implements schedule changes (day time vs. prime time) as setup by the broadcaster.

Broadcast Gateway

The **Broadcast Gateway**, has several functional processing blocks. First, it is responsible for IP Delivery and Signaling (as defined in A/330 and A/331). Data sources for the Services to be broadcast are delivered to the Broadcast Gateway via UDP over IP through a Gigabit Ethernet L3 switch using MMT (MPEG Media Transport) or ROUTE (Real-time Object delivery over Unidirectional Transport). Data sources can be either server based, and/or encoder based. The Broadcast Gateway also contains the Scheduler. The Scheduler uses configuration data from the System Resource Manager to configure the ALP Processor (ATSC Link-layer Protocol). The configuration data instructs the Scheduler how to allocate physical capacity to the Services such as the number of PLP's, the configuration of each and the capacity of each PLP. The Scheduler determines Frame lengths, subframe sizing, waveform configuration, and creates the preamble that is used in the PHY layer.

Finally, the ALP processor is the link layer that transports the data from the network layer (Services) to the physical layer (RF) as specified in A/324. Operations including encapsulation, compression and link layer signaling are referred to as the ALP and packets created using this protocol are called ALP packets. ALP data packets are mapped into PLP's as previously noted by the Scheduler.

IP Contribution Network

The studio or Network Operations Center (NOC) feeds the IP contribution network (also known as the Studio to Transmitter Link or STL). The NOC contains the Broadcast Gateway, System Resource Manager, and the data sources / program encoders.

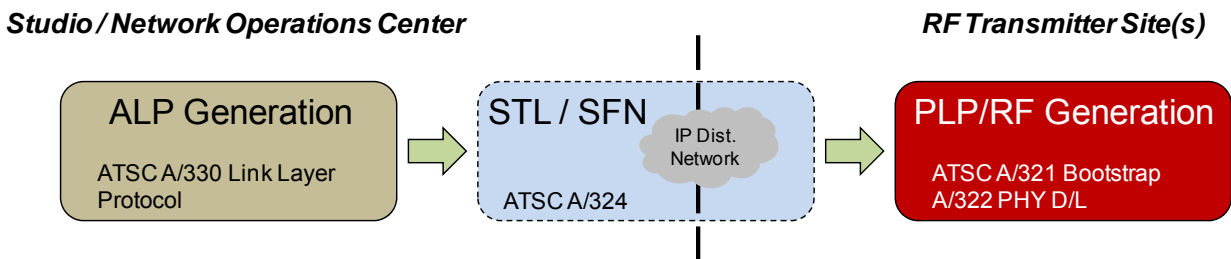

The IP contribution network essentially bridges the IP Transport (ALP as defined in A/330) and the RF Physical layers (PLP/RF waveform as defined in A/321 and A/322). ATSC standard A/324 has been drafted to define the interconnection between these Transport and Physical layers as well as additional protocols (ALPTP and STLTP) that are necessary to manage the IP traffic over the contribution network. The IP contribution network, whether microwave, fiber, or satellite, has to be capable of carrying high speed (250Mbps up to 1Gbps) IP/UDP IPv4 traffic with port addressing capabilities. The contribution network incorporates SMPTE 2022-1 for Error Correction Coding (ECC) of the IP data passed through the network.

DTV Exciter

Finally at the transmitter site, the exciter needs to be ATSC 3.0 compatible such as the Hitachi-Comark **EXACT** ATSC exciter. If an SFN is planned, the all DTV excitors will require GPS for precise frequency control. Assuming the transmitter site(s) are not co-located with the studio, an ATSC 3.0 compliant contribution network needs to be implemented. The functional blocks of the exciter are shown in the diagram below along with the tasks and in/out interfaces.

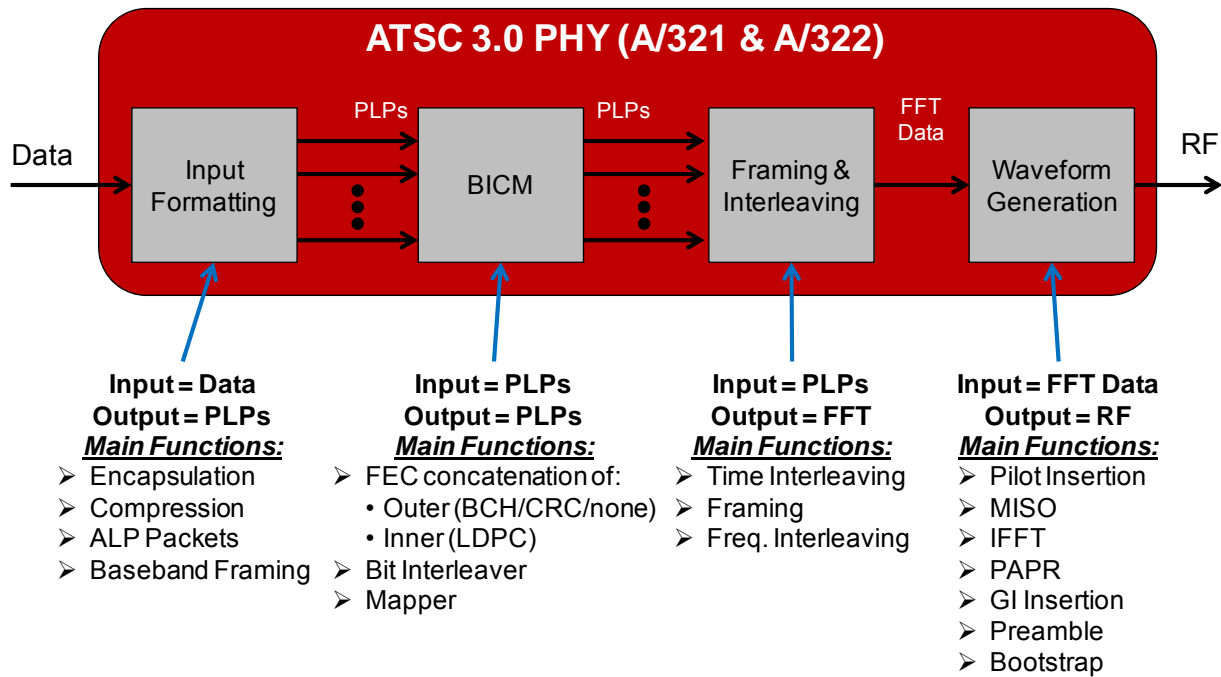

➤ DTV Transmitter Considerations

Most existing DTV transmitters can be upgraded from ATSC 1.0 to 3.0. Upgrades generally involve replacing or swapping the existing exciter with one that is either upgradeable (such as the EXACT-ATSC) or with a full ATSC 3.0 compliant exciter once the units become production ready. Beyond the exciter there are other considerations to the transmitter infrastructure that should be considered, especially in light of the FCC incentive auction and subsequent channel re-packing exercise that is about to commence.

RF Power Ratings – RF power amplifiers are generally rated by their average RF output power capability. DTV waveforms (VSB, OFDM) have different peak to average power ratios; 8VSB is generally 7dB and OFDM is generally 10dB (without PAPR). ATSC 3.0 has the ability to utilize PAPR with either Tone Reservation (TR) or Active Constellation Extension (ACE) to reduce the peak power requirements of the ATSC 3.0 signal. Combining PAPR with Hitachi-Comark’s Emmy Award Winning Digital Adaptive Precorrection (DAP™) technology, the typical amplifier de-rating between VSB and OFDM is 20%.

The amplifier technology used in existing solid state and IOT based transmitters need to be sized/rated so that these peaks are not compressed. Otherwise the DTV signal will have distortion and MER and SNR performance will be reduced. A general rule of thumb is that an existing ATSC 1.0 transmitter from Hitachi-Comark rated at 10kW average will need to be de-rated by 20% producing roughly 8kW. However check with your factory representative for confirmation by product line and vintage.

PARALLAX™

With rapid changes over the past 18 - 24 months in RF device technologies and design techniques to improve efficiency, Hitachi Kokusai Electric Comark developed the PARALLAX™, a new medium and high power solid state transmitter for the US market. The transmitter utilizes the latest LDMOS FET devices from Ampleon. These devices provide the best efficiency in the industry utilizing a broadband asymmetric Doherty configuration. Asymmetric Doherty has the benefit of delivering the same output power in ATSC 1.0 (8VSB) and ATSC 3.0 (OFDM).

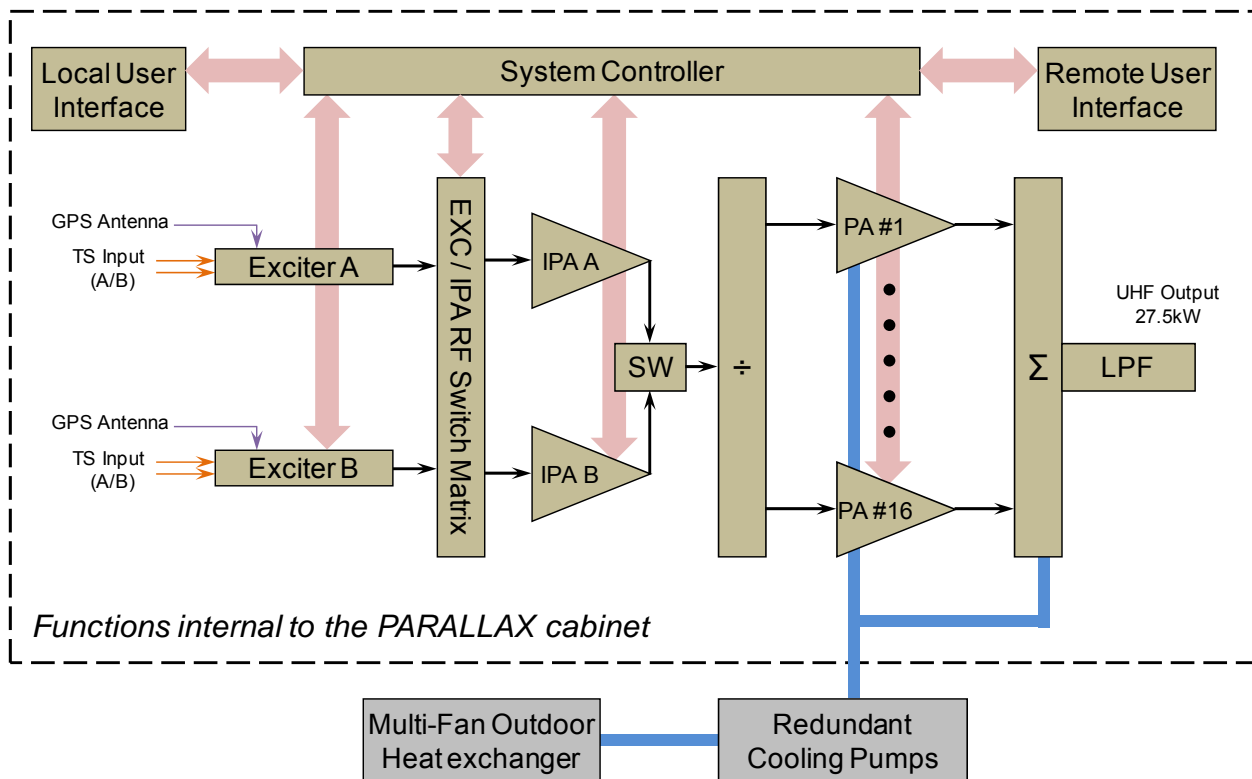
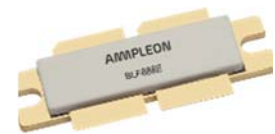

➤ ATSC 3.0 Acronyms and Glossary

AGWN {Additive Gaussian White Noise} – is a basic noise model used in Information theory to mimic the effect of many random processes that occur in nature.

ALP {ATSC Link layer Protocol} – is the output packet format between the data encapsulation/compression and baseband framing functions of the signal input formatting.

Base Layer – is also referred to as Layer 1 of a two-layer LDM system

BCH {Bose, Chaudhuri, Hocquenghem} – is one of two options for linear error coding used in the BICM processing block for outer code correction (CRC is the other). For ATSC 3.0, a 12 bit correctable BCH provides both error detection and correction capabilities.

BICM {Bit-Interleaved Coded Modulation} – is the PLP processing block that consists of three functions including the FEC, Bit Interleaver, and Mapper.

Bootstrap – is also known as the System Discovery and Signaling (A/321) and is the universal entry point into the digital transmission signal. It precedes the preamble and is part of the overall ATSC 3.0 frame structure. The bootstrap signals the FFT size, guard interval, and scattered pilot pattern of the preamble symbols.

Broadcast Gateway – a device that resides at the studio or NOC that provides, IP delivery and signaling, ALP processing, SFN processing, and scheduler functions.

Code Rate – is the ratio of useful data to total data with redundancies included. For ATSC 3.0 there are 12 different code rates available (2/15 through 13/15)

Core Layer is the basic layer of an LDM system.

CRC {Cyclic Redundancy Check} – is one of two options for linear error coding used in the BICM processing block for outer code correction (BCH is the other). For ATSC 3.0, a 32 bit CRC provides only error detection and no error correction capabilities.

CTI {Convolutional Time Interleaver} – is enabled when there is only a single PLP or when LDM is used with a single core-layer PLP.

Enhancement Layer is the Layer 2 of a two layer LDM system.

FDM {Frequency Division Multiplexing} – different configurations use different carrier frequencies

FEC {Forward Error Correction} – is the process whereby additional bits are added to a digital signal at the transmission side that allows a receiver to detect bit errors and correct the signal.

FEL {Future Extension Layer} – is an extension layer for an LDM system.

FFT {Fast Fourier Transform} – is a process that converts a signal from its original time domain to a representation in the frequency domain. FFT takes place in the framing & interleaving processing block of ATSC 3.0 exciter.

GI {Guard Interval} – guard interval is used to introduce immunity to propagation delays, echoes, and reflections. ATSC 3.0 has 12 user selectable GI lengths (192, 384, 512, 768, 1024, 1536, 2048, 2432, 3072, 3648, 4096, and 4864) for echo protection.

IFFT {Inverse Fast Fourier Transform} – is the process that converts a signal from its original frequency domain to a representation in the time domain (ODFM symbol). IFFT takes place in the waveform generation processing block of ATSC 3.0 exciter.

L1 Basic – is part of the preamble following the “bootstrap” and carries the most fundamental signaling information as well as data necessary to decode L1 Detail.

L1 Detail – is part of the preamble following the L1 Basic. It has the information necessary to decode subframes including the ModCod, number of PLP’s, pilot pattern, FEC, etc.

LDM {Layered Division Multiplexing} – is a multiplexing scheme where multiple RF signals are layered on top of one another. A 2 layer system has Core layer (more robust ModCod) and an Enhanced layer (less robust ModCod). The Enhanced layer is “injected” between -3 and -10dB relative to the Core layer.

LDPC {Low-Density Parity Check} – is a linear error correcting code, used in the BICM processing block for inner code correction. Inner code correction is mandatory in ATSC 3.0. There are two different sizes of the LDPC code; 64800 bits and 16200 bits.

LLS {Low Level Signaling} – is signaling information which supports rapid channel scans and bootstrapping of Service acquisition by the receiver. It operates below the IP layer and includes a table that points to the Service List Table (SLT), Regional Ratings Table (RRT), System Time (ST), Common Alerting Protocol (CAP), and Service Layer Signaling (SLS) tables.

LMT {Link Mapping Table} – provides a list of upper layer sessions carried in a PLP.

MISO {Multiple Input Single Output} – one of three frame types (SISO, MISO, MIMO). MISO is a pre-distortion technique that artificially de-correlates signals from multiple transmitters in an SFN in order to minimize potential destructive interference.

MIMO {Multiple Input Multiple Output} – one of three frame types (SISO, MISO, MIMO). MIMO improves system robustness via additional spatial diversity (2 Tx antennas, 2 Rx antennas). The spatial diversity is usually combined with polarization diversity (H-Pol & V-Pol).

ModCod {**M**odulation and **C**ode Rate} – is the combination of modulation and coding rate that together determine the size of the baseband packet.

NOC {**N**etwork **O**perations **C**enter} – is the facility that contains the System Resource Manager, data sources / program encoders, and the Broadcast Gateway. The NOC is sometime also called the studio.

NUC {**N**on-**U**niform **C**onstellation} – is a constellation (QAM) with a non-uniform spread of the constellation points.

PAPR {**P**eak-to-**A**verage **P**ower **R**eduction} – modifies the OFDM signal via Tone Reservation (TR) and/or Active Constellation Extension (ACE) to reduce the peak power requirements of the ATSC 3.0 signal.

Preamble – contains L1 control signaling applicable to the remainder of the frame. The preamble has two parts: L1 Basic and L1 Detail.

PLP {**P**hysical **L**ayer **P**ipe} – is a structure specified to an allocated capacity and robustness that can be adjusted to broadcaster needs. Maximum number of PLP's in a RF channel is 64. Receivers are expected to be able to decode at least 4 PLP's in parallel.

RTP/UDP/IP – Real-Time Protocol *over* User Datagram Protocol *over* Internet Protocol

Scheduler – is a functional processing block at the studio or NOC within the broadcast gateway that allocates physical capacity to the Services.

Services – is the collection of broadcast data and content including but not limited to mobile content, Standard Definition (SD) video, High Definition (HD) video, High Dynamic Rate (HDR) video, Emergency Alert System (EAS) data, and metadata.

SISO {**S**ingle **I**nput **S**ingle **O**utput} – one of three frame types (SISO, MISO, MIMO). SISO is signal processing with only one transmit antenna and only one receive antenna.

Subframe – immediately follows the preamble. If multiple subframes are present in a frame, then those subframes shall be concatenated together.

System Resource Manager – a device that resides at the studio or NOC that provides configuration data to the other elements of the ATSC 3.0 system including how many PLP's, the Services defined with those PLP's, and the implementation of the Service schedule(s).

TDM {**T**ime **D**ivision **M**ultiplexing} – is the concatenation in time of multiple PLPs within a subframe can be achieved simply by using non-dispersed PLPs instead of dispersed PLPs.

➤ **What Makes Hitachi-Comark Unique?**

Hitachi Kokusai Electric Comark LLC has an unparalleled history in broadcasting. With over 40 years of innovation and continuous service, we have been delivering leading-edge analog and digital television systems worldwide. Comark has won multiple awards and is the only transmitter vendor to win a technical Emmy for transmitter technology. So whether you are looking for a simple exciter upgrade to get an ATSC 3.0 signal on the air or a full-blown package with integrated network management, redundancy, and factory integration and test, Comark has you covered.



Hitachi-Comark provides end-to-end solutions to avoid the complications of multiple vendor interface issues. Open architecture supports interoperability between modules and interfaces with third-party sub systems.

➤ **SALES**

Please contact your authorized Hitachi-Comark sales representative for more information or send an e-mail to sales@comarktv.com.

➤ **SUPPORT**

Please see www.comarktv.com for product information and specifications. To contact customer service, send an email to support@comarktv.com.